



AIRCRAFT ACCIDENT REPORT
OCCURRENCE NUMBER 00/315
AEROSPATIALE AS 350 D HELICOPTER
ZK-HKV
TAPORA, NORTHLAND
10 FEBRUARY 2000

Glossary of abbreviations used in this report:

CAA	Civil Aviation Authority
E	east
km	kilometre(s)
m	metre(s)
mm	millimetre(s)
NZDT	New Zealand Daylight Time
S	south
UTC	Coordinated Universal Time

AIRCRAFT ACCIDENT REPORT

OCCURRENCE No. 00/315

Aircraft type, serial number and registration:	Aerospatale AS 350 D helicopter, 1388, ZK-HKV
Number and type of engines:	1 Lycoming LTS-101-600A-3
Year of manufacture:	1980
Date and time:	10 February 2000, 1850 hours* approx
Location:	Tapora, Northland Latitude: S 36° 21.6' Longitude: E 174° 19.3'
Type of flight:	Agricultural: spraying
Persons on board:	Crew: 1
Injuries:	Crew: 1 fatal
Nature of damage:	Aircraft destroyed
Pilot-in-command's licence	Commercial Pilot Licence (Helicopter)
Pilot-in-command's age	30 years
Pilot-in-command's total flying experience:	3930 hours, 1500 on type
Information sources:	Civil Aviation Authority field investigation
Investigator in Charge:	Mr A J Buckingham

* Times are NZDT (UTC + 13 hours)

Synopsis

The Civil Aviation Authority was notified of the accident at 1911 hours on Thursday 10 February 2000. The Transport Accident Investigation Commission was in turn notified shortly thereafter, but declined to investigate. A CAA site investigation was commenced next morning.

The helicopter was on an agricultural spraying flight, and was returning to the loading site after applying a load of chemical. Part of the spray equipment became detached from the helicopter in flight and was struck by the main rotor, resulting in the separation of the main rotor transmission from the airframe. The pilot was killed and the helicopter destroyed in the subsequent ground impact.

1. Factual information

1.1 History of the flight

- 1.1.1 On 10 February 2000, the pilot had arranged to spray crops for three clients at Tapora, some 20 km to the west of Wellsford. Before the planned spraying operations he flew a passenger charter in the Auckland area, and had arranged on completion of the charter to meet his loader at Kaipara Flats aerodrome.
- 1.1.2 The helicopter landed at Kaipara Flats about 1515 hours, and the pilot and loader fitted the spray equipment. This comprised a motor-driven pump mounted on the left skid, spray tanks on either side of the aft fuselage and one spray boom each side. The booms were each supported by a tubular brace attached to a hard point on the aft fuselage and to a saddle about the boom mid-point; and a tubular stainless steel drag brace between that saddle and an eyebolt near the front of each skid.
- 1.1.4 The pilot and loader arrived at the operating site about 1630 hours, setting up the loading base adjacent to the first crop to be sprayed. This crop was completed uneventfully after seven loads, and a second crop some 2 km distant was finished in three loads. The third crop to be treated was 3 km away from the loading point.
- 1.1.5 Both the loader and the manager of the property on which the loading point was situated observed the helicopter returning from the first application on the third crop, and the loader made ready to replenish the spray tanks when the helicopter landed.
- 1.1.6 The loader had just donned his earmuffs when he and the manager heard a loud bang, and looked around to see some fluttering white objects dropping out of sight behind an intervening maize crop on a low rise. Both were aware that something had happened to the helicopter, but could not tell what at this time.
- 1.1.7 The loader and manager drove immediately to where they had seen the objects fall. They found the wreckage of the helicopter and that the pilot had sustained fatal injuries.

1.1.9 The accident occurred in daylight, about 1850 hours NZDT, at Tabora, Northland at an elevation close to sea level. Grid reference 260-Q09-291355, latitude S 36° 21.6', longitude E 174° 19.3'.

1.2 Injuries to persons

<i>Injuries</i>	<i>Crew</i>	<i>Passengers</i>	<i>Other</i>
Fatal	1	0	0
Serious	0	0	0
Minor/None	0	0	

1.3 Damage to aircraft

1.3.1 The helicopter was destroyed.

1.4 Other damage

1.4.1 A short length of a post-and-wire fence was damaged by the impact of the transmission and rotor.

1.5 Personnel information

1.5.1 The pilot, aged 30, held a Commercial Pilot Licence (Helicopter) first issued in 1988, and a current Class 1 medical certificate endorsed with a requirement for distance-vision spectacles. His licence was endorsed with an AS350 type rating, an Agricultural rating and a Chemical rating.

1.5.2 He had flown a total of 3930 hours on helicopters, including some 1500 on the AS 350 helicopter series. His last biennial flight review and proficiency check were carried out on 23 April 1999.

1.5.3 The loader, aged 17, had worked for the operator for two months at the time of the accident.

1.6 Aircraft information

1.6.1 Up to the time of the accident ZK-HKV had accrued a total of 9511.6 hours in service. The next scheduled maintenance was a 100-hourly check, due in 5.9 hours.

1.6.2 The helicopter had a current non-terminating Airworthiness Certificate, issued on 10 April 1995.

1.6.3 Flight Manual Supplement RJAD43 contained the limitations, and normal and emergency procedures for the spray system. Section 1, "General" introduced the system as follows:

“Marine Helicopters Ltd Modification RJAD43 installs a complete agricultural spray system to Aerospatiale AS 350D ZK-HKV. The rear cargo doors are removed to accommodate two fuselage mounted fibreglass tanks. A system of interconnecting pipe-work with cam-lock fittings is used, mounted beneath the helicopter, with two braced spray booms which sweep forward. A petrol-driven motor and pump assembly is bolted to the port skid. The pneumatic spray valve must be fed by an approved bleed air supply.”

- 1.6.4 When the modification drawings were examined, it was found that the boom and support strut configuration at the time of the accident differed from that depicted. The drawings called for two support struts and two drag braces on each boom, but as described in paragraph 1.1.2, there was only one of each fitted. See Diagrams 1 and 2.
- 1.6.5 The spray booms had been supplied new in 1999, complete with the two pairs of struts per side. These replaced the original set, which was of lighter construction, the braces being of aluminium alloy rather than the stainless steel of the replacement set. It was found that, with the new equipment installed, the loader’s access to the spray tanks was severely impeded, so the booms were reconfigured to one pair of braces per side. This occurred about the end of September 1999 and was done without the knowledge of the company’s chief pilot or the engineering staff.
- 1.6.6 Each drag brace was attached to an eyebolt on a float fitting near the front of its respective skid, by means of a bolt and nut, the nut normally being locked by a spring clip. The drawings specified an AN4 bolt (an aviation specification ¼-inch bolt), a corresponding self-locking nut and a spring clip. On the day of the accident, the left brace was attached with a bolt of unknown type and self-locking nut; a hole had been drilled through the nut and the bolt to accommodate the spring clip. Once the spring clip had been fitted, the complete assembly was wrapped with plastic insulation tape for additional security. It had been inferred initially from the loader’s statement that no spring clip had been used, and the tape used as a substitute, leading to the nut backing off and being lost. However, the loader later confirmed that a clip had in fact been used, and clarified the description of the fastening.
- 1.6.7 The loader reported that the nut was not tightened fully, but only to a point where there was still about 10 mm of the bolt shank exposed (in other words, the joint was not securely clamped). This had been the practice in force when he joined the company, and he was not in a position to know if the bolt was of aviation grade.

1.7 Meteorological information

- 1.7.1 The weather at the time of the accident was overcast with light winds and good visibility.

1.8 Aids to navigation

- 1.8.1 Not applicable.

1.9 Communications

1.9.1 Not applicable.

1.10 Aerodrome information

1.10.1 Not applicable.

1.11 Flight recorders

1.11.1 Not applicable.

1.12 Wreckage and impact information

1.12.1 During the site investigation, it was immediately evident that the main rotor and transmission had separated from the airframe in flight. The rotor and transmission struck the ground 24 m short of the first impact marks made by the fuselage.

1.12.2 The fuselage struck the ground in an upright attitude, slightly nose-down, with about 30° of right yaw. It rolled 360° to the left on impact. The skids were broken off in the initial ground contact, and the forward upper fuselage crushed during the rollover.

1.12.3 Some 140 m back along the observed flight path was a section of the transmission cowling, some pieces of rotor blade, and foam from the Starflex rotor head. Abeam that point, about 50 m to the left of the flight path, were some pieces of rotor blade skin and one arm of the Starflex head.

1.12.4 One main rotor blade (the red¹ blade) exhibited a substantial strike mark on the stainless steel leading edge about 300 mm inboard of the tip. At the moment of impact, the object that was struck was projecting upward from below the blade at an angle of 24° from the horizontal. There was no visible material transfer from the object to the leading edge of the blade.

1.12.5 The next rotor blade (yellow) in the rotational sequence also had a strike mark on the leading edge, 2160 mm from the tip. Similarly, there was no material transfer evident.

1.12.6 It was apparent that the leverage exerted by the strike on the red blade had caused the failure of the corresponding arm of the Starflex head. A failure of this nature removes the lead-lag restraint normally applied to the rotor blade, allowing the blade to move from its fixed angular relationship to the other two blades. This results in the displacement of the centre of gravity of the entire rotor system from its normal location on the mast centreline, and the application of gross cyclical forces on the transmission mountings.

1.12.7 The transmission mount tubes had failed in tensile overload, consistent with the application of the forces described in 1.12.6. The transmission cowling, which

¹ Rotor blades and their corresponding linkages are colour coded for identification.

had landed close to the main wreckage, bore evidence of a heavy impact vertically upwards from within, which had torn it free of its restraints.

- 1.12.8 Two pieces of the spray system could not be accounted for at the site, despite extensive searching. They were the left-hand stainless steel drag brace, 2840 mm in length, and the outer portion (about 820 mm) of the left-hand spray boom. It was not until one month later that the farm manager found these, well outside the initial search area. They were part-way up a hill, some 500 m to the left of the flight path, roughly abeam the start of the wreckage trail.
- 1.12.9 Both pieces had impact marks matching the strike marks on the rotor blades. The stainless steel drag brace had been struck by the tip of the red blade and the piece of aluminium alloy boom had been hit by the yellow blade.
- 1.12.10 At the accident site on 11 February, one of the searchers found a small circle of black insulation tape on the ground, at a point some 200 m before the beginning of the wreckage trail, several metres to the left of the flight path. The chief pilot reported that the tape was identified as that which had been wrapped around the drag brace attachment bolt and nut (described in 1.6.6). Neither the bolt nor the nut was found, however.

1.13 Medical and pathological information

- 1.13.1 Post-mortem examination found that the pilot had died of injuries consistent with the nature of the ground impact.
- 1.13.2 There was no evidence of any pre-existing condition or incapacity which would have impaired the pilot's ability to perform his duties, and routine toxicological tests disclosed nothing of significance.

1.14 Fire

- 1.14.1 Fire did not occur.

1.15 Survival aspects

- 1.15.1 The pilot had a shoulder harness available, but had chosen not to wear it. Each front seat was fitted with a vinyl pull-on seat cover, which covered the shoulder harness straps mounted on the back of the seat. Slots were cut in the vinyl cover to allow access to the shoulder harness when required.
- 1.15.2 The pilot was not wearing a safety helmet at the time of the accident.
- 1.15.3 The pathologist indicated that the fatal injuries sustained by the pilot were consistent with lack of upper body restraint.

1.16 Tests and research

- 1.16.1 Nil.

1.17 Organisational and management information

- 1.17.1 The pilot operated from an outstation remote from the company's main base at Ardmore Aerodrome. The helicopter was normally flown to Ardmore when maintenance was due. Before the helicopter was flown in for maintenance, the spray equipment was removed and stowed at the outstation. The chief pilot and the engineering staff were thus unaware that it had been modified, and that the method of attaching the braces was non-standard.

1.18 Additional information

- 1.18.1 The pilot was permitted by Civil Aviation Rules Part 43, Appendix A, to fit and remove the spray equipment to and from the helicopter, but was not authorised to carry out modifications or changes to the equipment itself.
- 1.18.2 Civil Aviation Rule 91.201 required the pilot to be satisfied that the aircraft was in condition for safe flight.

1.19 Useful or effective investigation techniques

- 1.19.1 Nil.

2. Analysis

- 2.1 Two items merit discussion in the analysis of this accident: the first is the modification of the spray equipment so that it differed from design specification, and the second is the method of attaching the drag braces to the airframe.
- 2.2 The reconfiguring of the spray equipment undoubtedly made the loader's task easier, but the relocation of the support points on the booms meant that either boom would have been more susceptible to fatigue failure. The longer unsupported outboard section would be more prone to flexure and possibly subject to loadings outside the design criteria. Although this was not a factor that contributed to this accident, it serves to illustrate the possible consequences of departure from design specifications.
- 2.3 The available evidence suggests that the bolt holding the forward end of the left drag brace to its skid fitting failed in flight. The inherent flexibility of the drag brace, combined with the natural vibration of the skid assembly in flight, meant that the bolt and nut had not only to restrain aerodynamic loads but also to resist any relative movement between the two members. With the nut not fully tightened, the relative movement would have applied a repetitive bending load to the shank of the bolt. The loss of the bolt would then allow the drag brace to flail.
- 2.4 The drag brace was struck by one rotor blade, and the force of the strike probably dislocated the spray boom, flinging it into the path of the next blade. (The time interval between successive blades at normal operating rpm is about 0.05 seconds.) For the components to land where they did, the strikes would have to

have occurred at about the “seven o’clock” position on the rotor (as viewed from above).

- 2.5 The force of the first strike, acting through an arm of almost the length of one rotor blade, produced sufficient leverage to cause part of the rotor head to fail. The rotor head failure disrupted the fixed angular relationship between the blades, and the resultant massive imbalance forces tore the transmission and rotor assembly free of the airframe.
- 2.6 From that point, the pilot’s chances of survival were minimal, even had he been wearing a safety helmet and shoulder harness.
- 2.7 The pilot and loader were probably not aware of the importance of a secure, tight fastening of the drag braces to the skids, nor of the significance of using only aviation-specific fasteners.

3. Conclusions

- 3.1 The pilot was appropriately licensed, rated and fit to carry out the series of flights.
- 3.2 The helicopter was airworthy at the time of the accident.
- 3.3 The spray equipment configuration had been modified from the original design without the knowledge of the operator, but this was not a factor contributing to the accident..
- 3.4 The drag braces had been attached to their mounting points on the respective skids using a non-standard method, in that the joints were not securely clamped by the bolt and nut.
- 3.5 The bolt securing the left drag brace to the skid failed in flight, allowing the drag brace to flail.
- 3.6 The unrestrained drag brace and the end of the left spray boom were struck by the main rotor, causing a catastrophic failure of the rotor head.
- 3.7 The resulting imbalance tore the main transmission from the airframe, rendering the helicopter incapable of further flight.
- 3.8 Both the pilot and the loader were probably unaware of the potential dangers of using a non-standard method to attach the drag braces to the airframe.

4. Safety actions

- 4.1 Shortly after the accident, the Chief Pilot highlighted to company pilots the need to check the attachment points on spray equipment, and of the need to wear safety helmets and shoulder harness. The monitoring of equipment held at outstations was also reviewed.
- 4.2 A suitable educational article was to be drafted for *Vector* magazine.

5. Observations

- 5.1 Although no specific safety recommendations were made as a result of the investigation of this accident, the circumstances of this accident serve as a stark reminder that even a seemingly minor departure from specification can have dire consequences.

(Signed)

Richard White
Manager Safety Investigation
16 January 2001

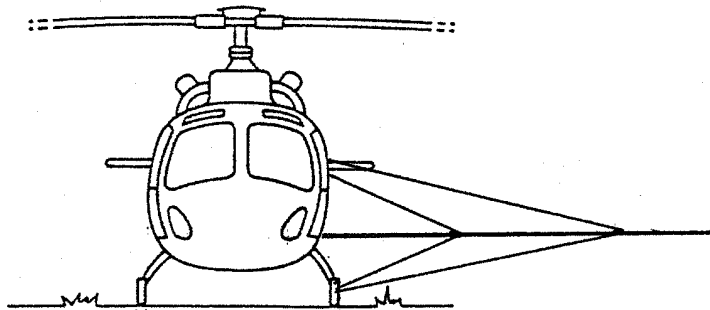
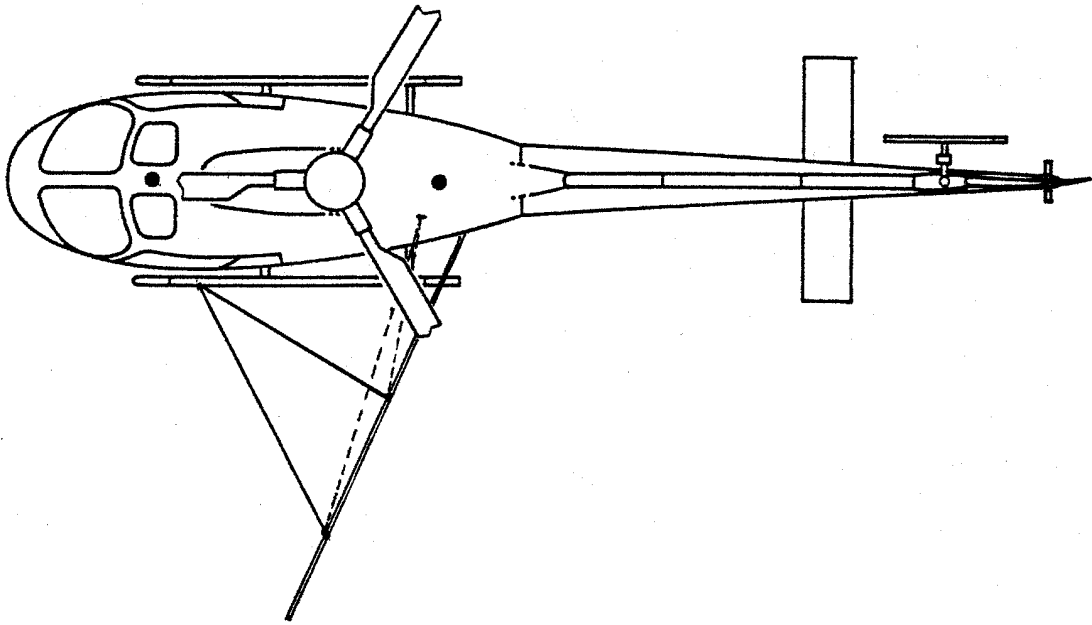

**Diagram 1: Spray equipment configuration as approved
(Only one side shown for clarity)**

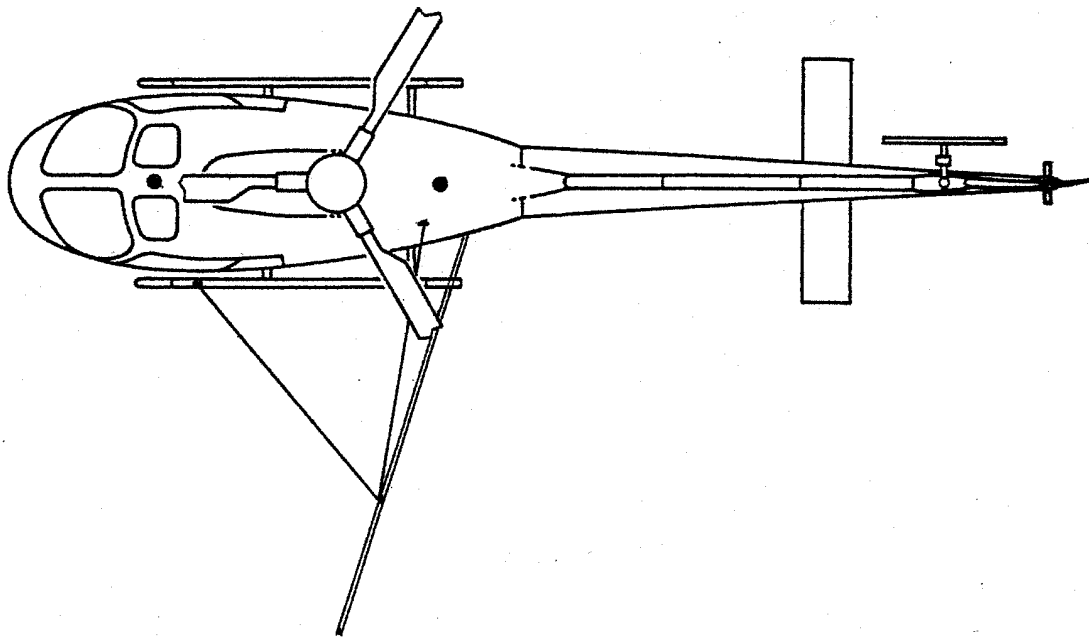

Diagram 2: Changed spray equipment configuration