

Revision 4

Aerodrome Standards and Requirements—

18 December 2009

**Aeroplanes at or below 5700 kg MCTOW—Non Air
Transport Operations**

General

Civil Aviation Authority advisory circulars (ACs) contain information about standards, practices, and procedures that the Director has found to be an **Acceptable Means of Compliance (AMC)** with the associated rule.

Consideration will be given to other methods of compliance that may be presented to the Director. When new standards, practices, or procedures are found to be acceptable they will be added to the appropriate AC.

Purpose

This AC describes an acceptable means of compliance with standards for the operation of:

- aerodromes serving aeroplanes at or below 5700 kg MCTOW on non air transport operations; and
- aeroplanes at or below 5700 kg MCTOW on non air transport operations to facilitate compliance with the use of aerodrome requirements under Part 91.

Related Rules

This AC relates specifically to Part 139, in particular to rule 139.307 - *Use of aerodromes – non-air transport aircraft other than helicopters* and rule Part 91, in particular to rule 91.127 *Use of aerodromes*.

Change Notice

Revision 4 corrects a formatting error for the location of the Figure title for Figures 3-1, 3-2, and 4-1.

Published by
Civil Aviation Authority
PO Box 3555
Wellington 6140

Authorised by
Manager Rules Development

Table of Contents

CHAPTER 1 — GENERAL	3
1.1 Introduction	3
1.2 Applicability	3
1.2 Definitions	3
CHAPTER 2 — PHYSICAL CHARACTERISTICS	5
2.1 Runways 5	
2.2 Runway strip	6
2.3 Runway starter extensions.....	6
2.4 Taxiways 7	
CHAPTER 3 — OBSTACLE LIMITATION SURFACES	9
3.1 General 9	
3.2 Day VFR Runway	9
3.3 Night or instrument approach runway	11
CHAPTER 4 — WATER AERODROMES	13
4.1 General 13	
4.2 Water channel.....	13
4.3 Obstacle limitation surfaces.....	13
CHAPTER 5 — VISUAL AIDS FOR NAVIGATION	16
5.1 Wind direction indicator (Windssock).....	16
5.2 Markers and markings.....	16
5.3 Aerodrome lighting	19
5.4 Aerodrome lighting outages.....	22
5.5 Portable lighting	22
5.6 Reflectors.....	22
5.7 Signs 22	
5.8 Visual aids for denoting restricted use areas.....	23

CHAPTER 1 — GENERAL

1.1 Introduction

1.1.1 In accordance with the requirements of rules 91.127 and 139.307 Use of Aerodromes, no place may be used as an aerodrome unless the place is suitable for the purpose of taking off or landing of the aircraft concerned.

1.1.2 This Advisory Circular, which is based on the ICAO Annex 14 standards and requirements for aerodromes, details the physical characteristics, the types of equipment and installations, and the associated standards that are acceptable to the Director for ensuring compliance with the requirements of Parts 91 and 139 for the non air transport operation of aeroplanes at or below 5700 kg MCTOW.

1.2 Applicability

1.2.1 This Advisory Circular applies to any place used as an aerodrome for taking off or landing of aeroplanes at or below 5700 kg MCTOW operating under Part 91 or on non air transport operations.

1.2.2 Operators of aeroplanes above 5700 kg MCTOW or conducting air transport operations should refer to advisory circular AC 139-6.

1.2 Definitions

Aerodrome —

- (a) means any defined area of land or water intended or designed to be used either wholly or partly for the landing, departure, and surface movement of aircraft; and
- (b) includes any buildings, installations, and equipment on or adjacent to any such area used in connection with the aerodrome or its administration.

Aerodrome reference field length means the minimum field length required for take-off at MCTOW, sea level, standard atmospheric conditions, still air, and zero runway slope.

Displaced threshold means a threshold not located at the extremity of a runway.

Inner horizontal surface means a specified portion of a horizontal plane located above an aerodrome and its immediate environment. This surface establishes the height above which it may be necessary to restrict the creation of new obstacles, or remove or mark existing obstacles, to ensure the safety of aircraft visually manoeuvring in the aerodrome circuit prior to landing.

Instrument runway means a runway intended for the operation of aircraft using instrument approach procedures.

Manoeuvring area —

- (a) means that part of an aerodrome to be used for the take-off and landing of aircraft and for the surface movement of aircraft associated with takeoff and landing; but
- (b) does not include areas set aside for loading, off-loading, or maintenance of aircraft.

Marker means an object displayed above ground level in order to indicate an obstacle or delineate a boundary.

Marking means a symbol or group of symbols displayed on the surface of the movement area in order to convey aeronautical information.

Movement area means that part of an aerodrome intended to be used for the take-off and landing of aircraft and for the surface movement of aircraft, and includes the manoeuvring area, maintenance areas, and aprons.

Obstacle means all fixed (whether temporary or permanent) and mobile objects, or parts thereof, that are located on an area intended for the surface movement of aircraft or that extend above a defined surface intended to protect aircraft in flight.

Obstacle limitation surfaces mean defined areas about and above an aerodrome intended for the protection of aircraft in the vicinity of an aerodrome.

Outer main gear wheel span means the distance between the outside edges of the main gear wheels.

Runway means a defined rectangular area on a land aerodrome prepared for the landing and take-off of aircraft.

Runway strip means a defined area including the runway, and stopway (if a stopway is provided), that is intended—

- (1) to reduce the risk of damage to an aircraft running off the runway; and
- (2) to provide obstacle protection for aircraft flying over the runway strip during take off or landing operations:

Runway starter extension means an additional runway length made available for take-off, prior to the normal runway end at the commencement of the takeoff run.

Taxiway means a defined path on a land aerodrome established for the taxiing of aircraft and intended to provide a link between one part of the aerodrome and another.

Threshold means the beginning of that portion of the runway usable for landing.

CHAPTER 2 — PHYSICAL CHARACTERISTICS

2.1 Runways

2.1.1 Many factors affect the determination of the orientation siting of runways. One important factor is the usability factor as determined by the prevalent winds in the area. Another important factor is the alignment for the provision of the related approach and takeoff climb surfaces.

Runway surface

2.1.2 The runway surface should be without irregularities and of sufficient strength for the takeoff and landing of aeroplanes.

Location of threshold

2.1.3 The landing threshold is normally located at the start of a runway, if there are no obstacles penetrating above the approach surface.

2.1.4 In determining that no obstacle penetrates above the approach surface, account should be taken of roads and railways that are in the approach area. If they are present, a height of 4.5 m should be allowed for road vehicles and 5 m for trains.

2.1.5 If an object extends above the approach surface and it cannot be removed, the threshold should be displaced to a position on the runway that provides the required obstacle free approach surface.

Width of runways

2.1.6 For a day VFR runway, the minimum runway width should be twice the outer main gear wheel span of the aeroplane to be operated.

2.1.7 For an instrument runway or a runway intended to be used at night, the minimum runway width should be not less than:

- (a) 18 m for aeroplanes with an aerodrome reference field length less than 800 m.
- (b) 23 m for aeroplanes with an aerodrome reference field length of 800 m or more.

Separation of parallel runways

2.1.8 When parallel runways are designed for simultaneous use under visual conditions only, the minimum distance between centre lines should be 120 m.

Slopes on runways

2.1.9 The average slope over the length of the runway should not exceed 1:50 for a two directional runway or 1:5 for a one directional runway.

2.1.10 Where local slope changes occur along the length of a runway, they should not exceed 1:50.

2.1.11 Where slope changes cannot be avoided:

- (a) a slope change between two consecutive slopes should not exceed 1:50; and
- (b) for a runway wider than 18 m there should be an unobstructed line of sight from any point 2 m above the runway to all other points 2 m above the runway within a distance of at least half the length of the runway; and

- (c) for a runway 18 m wide or less there should be an unobstructed line of sight from any point 1.5 m above the runway to all other points 1.5 m above the runway within a distance of at least half the length of the runway.

2.1.12 All slopes should be avoided in the touchdown area, which is the first 200 m from the threshold.

2.1.13 For a day VFR runway, the transverse slope should be such as to prevent the collection of water at any point and to this end should not exceed 1:40. Where surface erosion is a problem, the transverse slope may be increased up to 1:20 to preserve the established surface.

2.1.14 For an instrument runway or a runway intended to be used at night the transverse slope should not exceed 1:50 and should be consistent throughout the runway length. It should not exceed 1:30 when the steeper slope is required to preserve the established runway surface.

2.2 Runway strip

General

2.2.1 A runway should be symmetrically included in a runway strip.

Length of runway strips

2.2.2 A runway strip should extend beyond each end of the runway for a distance of at least:

- (a) 10 m where the runway is less than 800 m in length.
- (b) 30 m where the runway is 800 m or more in length.

Width of runway strips

2.2.3 For a day VFR runway the minimum width of the runway strip should be two and a half times the wing span of the aeroplane to be operated, or 30 m, whichever is the greater.

2.2.4 For an instrument runway or a runway intended to be used at night the minimum width of a runway strip should be 60 metres for aeroplanes with an aerodrome reference field length less than 800 m, and 80 metres for aeroplanes with an aerodrome reference field length of 800 m or more.

Slope of runway strips

2.2.5 All slopes should not exceed those for the runway by more than 1% except that to prevent the accumulation of surface water the transverse slope may be graded to a slope value of up to 1:20.

Strength and grading of runway strips

2.2.6 The runway strip should be constructed to minimise the hazards, or significant damage, to aircraft in the event of an accidental run off from the runway. The surface of the runway strip should be flush with the edge of the runway.

2.3 Runway starter extensions

2.3.1 A runway starter extension may be established where additional takeoff distance, takeoff run or accelerate-stop distance is required but physical limitations do not allow provision of the mandatory runway strip or runway width.

2.3.2 Specifications:

- (a) A runway starter extension should be of sufficient strength for the aeroplane to be operated, and if possible in line with the runway.

- (b) Provided the length of the extension does not exceed 150 m, it may be narrower than the runway but not less than two thirds of the runway width or less than twice the outer main gear wheel span of the aeroplane to be operated.
- (c) The starter extension strip width should not be less than the wing span of the largest aircraft to be operated plus 8 m.
- (d) The runway strip end need not be at right angles to the runway centre line. The minimum distance between the runway strip end and any point of the starter extension end, or that enlarged area needed for aircraft to turn, should not be less than the wing overhang of the aeroplane to be operated plus the greater of 8 m or 20 per cent of the wing span.

These distances may need to be increased to allow for the adverse effects of propeller blast — for example where the extension stops at a public road or footpath.

2.3.3 Starter extensions may require a taxiway lead-in or widening at the end to allow aircraft to turn.

2.4 Taxiways

Width of taxiways

2.4.1 The width of a taxiway should be 7.5 m or not be less than the outer main gear wheel span of the largest aircraft to use the taxiway plus 2 m, whichever is the greater.

Surface of taxiways

2.4.2 The surface of a taxiway should not have irregularities that may cause damage to the aeroplane structure.

Taxiway minimum separation distances

2.4.3 The minimum distance that should be provided between the centre line of a runway and the centre line of a taxiway, and the centre line of a taxiway and fixed obstruction, is as shown in Table 2-1.

Taxiway-holding positions

2.4.4 The holding position should be marked at a point no closer to the runway than the runway strip edge.

2.4.5 Where the taxiway is intended to be used at night the marker should be illuminated, either internally or externally, or the location of the holding position identified using a yellow light located no more than 3 m outside the taxiway edge at the holding position.

Refer 5.2.6 for information on markers for general use.

Table 2-1 Taxiway minimum separation distances

Wing span	Runway centre line and taxiway centre line	Taxiway centre line and fixed object
Up to but not including 15 m	37.50 m	16.25 m
15 m up to but not including 24 m	52.00 m	21.50 m

The distances given above represent ordinary combinations of runways and taxiways using the largest aircraft likely to use that combination. Where a specific aircraft type is to be used the clearances may be adjusted accordingly

This page is intentionally blank.

CHAPTER 3 — OBSTACLE LIMITATION SURFACES

3.1 General

3.1.1 Each runway should be provided with take-off climb and approach surfaces such that aeroplanes taking off or landing have a clear obstacle free surface over which to carry out the initial part of the climb or final part of the approach.

3.1.2 Any boundary fence or hedge should be sited so as to not penetrate the take-off climb/approach surface. Any boundary fence or hedge not exceeding 1.2 m in height may penetrate the transitional side surface.

3.2 Day VFR Runway

Take-off climb/approach surface

3.2.1 Each runway should have a takeoff climb and approach surface which should:

- (a) Rise from the end of the runway strip; and
- (b) Be obstacle free above a gradient of 1:20; and
- (c) Extend horizontally 1200 m from the inner edge; and
- (d) Have sides that are splayed outwards at the rate of 1:20; and
- (e) Not turn before 300 m from the inner edge, if a turn is necessary.

Refer to Figure 3-1.

3.2.2 If the 1:20 gradient rising from the runway strip end does not clear all obstacles, a displaced landing threshold should be marked at the position necessary to ensure that the approach surface clears the obstacles.

Transitional side surface

3.2.3 Each runway strip should have a surface clear of obstructions extending sideways and upwards from the sides of the runway strip and the approach/take-off surfaces. The surface should be at a gradient of 1:4 till it reaches a height of 2 m above the runway strip.

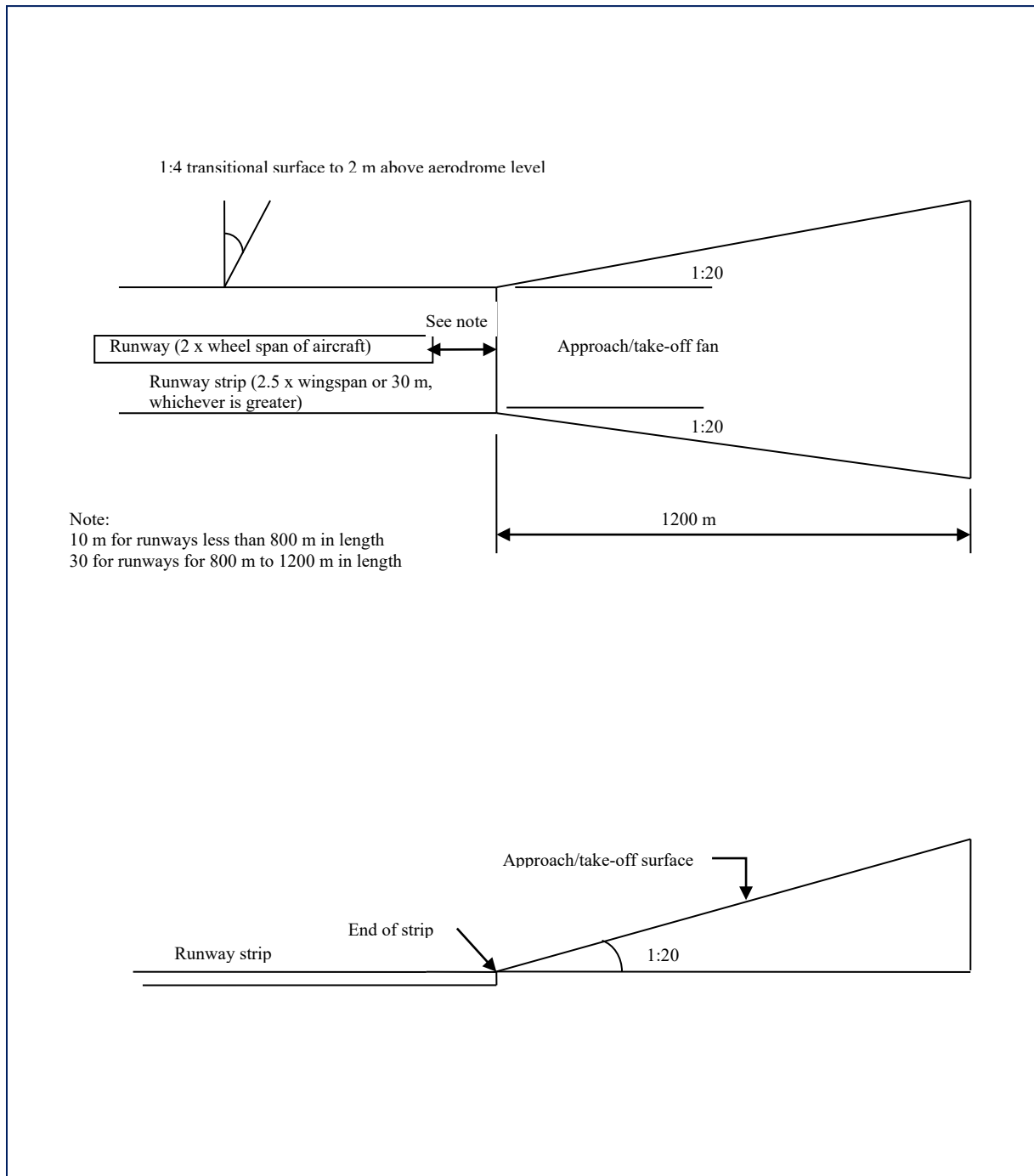

Figure 3-1. Day VFR runway obstacle limitation surfaces

3.3 Night or instrument approach runway

Take-off climb/approach surface

3.3.1 Each runway should have a takeoff climb and approach surface which should:

- (a) Rise from the end of the runway strip; and
- (b) Be obstacle free above a gradient of 1:40; and
- (c) Extend horizontally 1600 m for runways 800 m or less in length, and 2500 m for runways longer than 800 m but less than 1200 m in length, and
- (d) Have sides that are splayed outwards at the rate of 1:10; and
- (e) Not turn before 300 m from the inner edge, if a turn is necessary.

Refer Figure 3-2.

3.3.2 If the 1:40 gradient rising from the runway strip end does not clear all obstacles, a displaced landing threshold should be marked at the position necessary to ensure that the approach surface clears the obstacles.

Transitional surfaces

3.3.3 The transitional surfaces should slope upwards and outwards from the sides of the runway strip and the approach slope at a gradient of 1:5 to a height of 10 m above the strip, and then rise vertically to meet the inner horizontal surface.

3.3.4 The gradient of the transitional side surface should be measured in the vertical plane at right angles to the centre line of the runway.

Inner horizontal surface

3.3.5 An inner horizontal surface should be provided 45 m above the aerodrome elevation datum out to a distance of 2500 m from the runway centre line and the end of the strip.

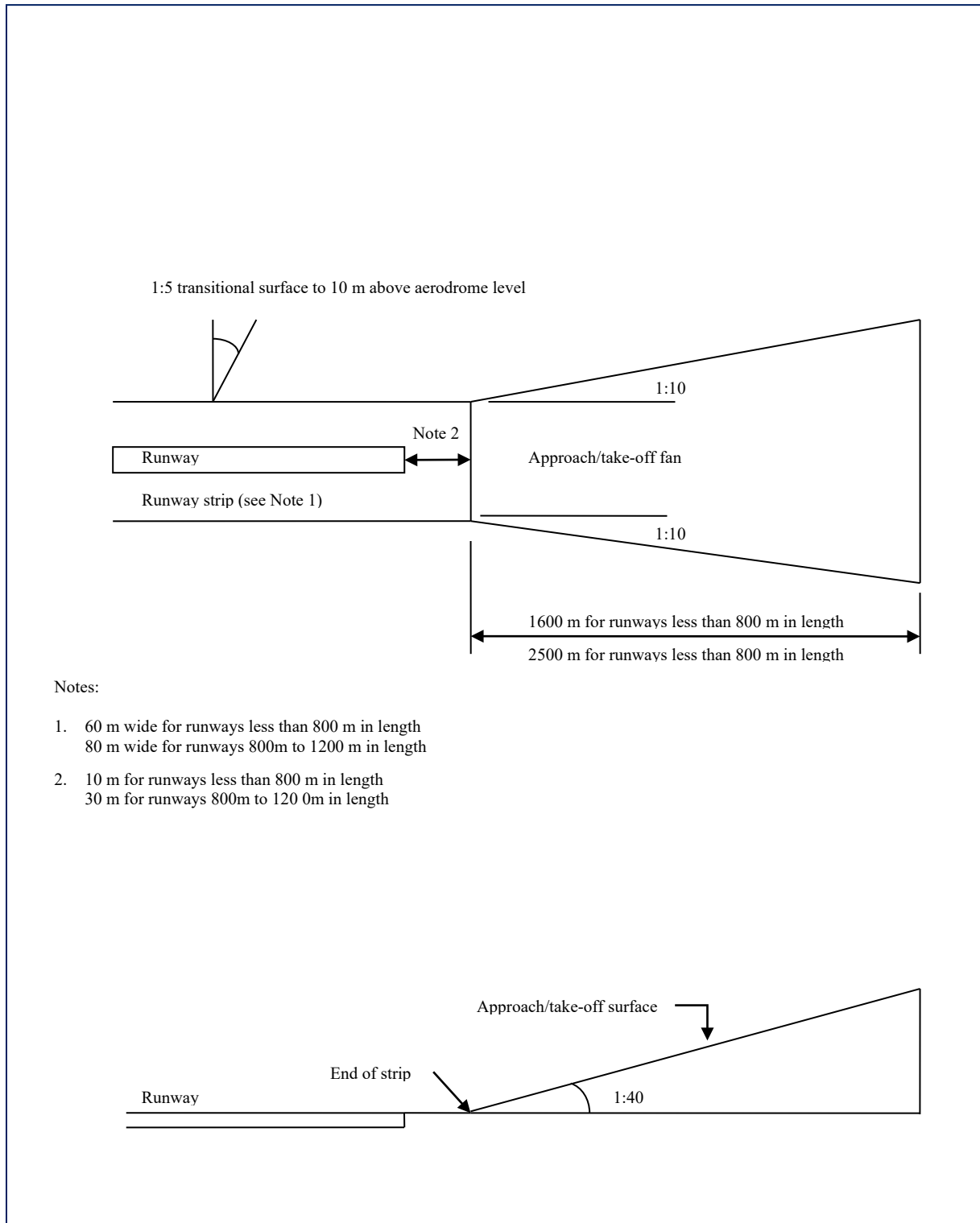

Figure 3-2. Night or instrument runway obstacle limitation surfaces

CHAPTER 4 — WATER AERODROMES

4.1 General

4.1.1 Any place used as an aerodrome in a tract of water should comply with the following specifications.

4.2 Water channel

4.2.1 The area of water used for the takeoff and landing of aeroplanes is called a water channel.

Water channel width

4.2.2 The minimum width of the water channel should be 60 m.

Water channel depth

4.2.3 The depth of the water channel should provide 1 m clearance below the hull or floats of the aeroplane when it is stationary at its maximum all-up weight.

4.2.4 A water channel should be clear of both stationary or moving vessels and other objects during flight operations.

Water channel additional area

4.2.5 There should be an additional area 30 m wide symmetrically surrounding the water channel to act as a protective buffer. This additional area need not consist of water but where it does, that area should be clear of moving objects, or vessels under way.

4.3 Obstacle limitation surfaces

4.3.1 Each water channel should have takeoff climb and approach obstacle free surfaces as prescribed for land aerodromes except that they should extend from the full width of the water channel ends. Refer Figure 4-1.

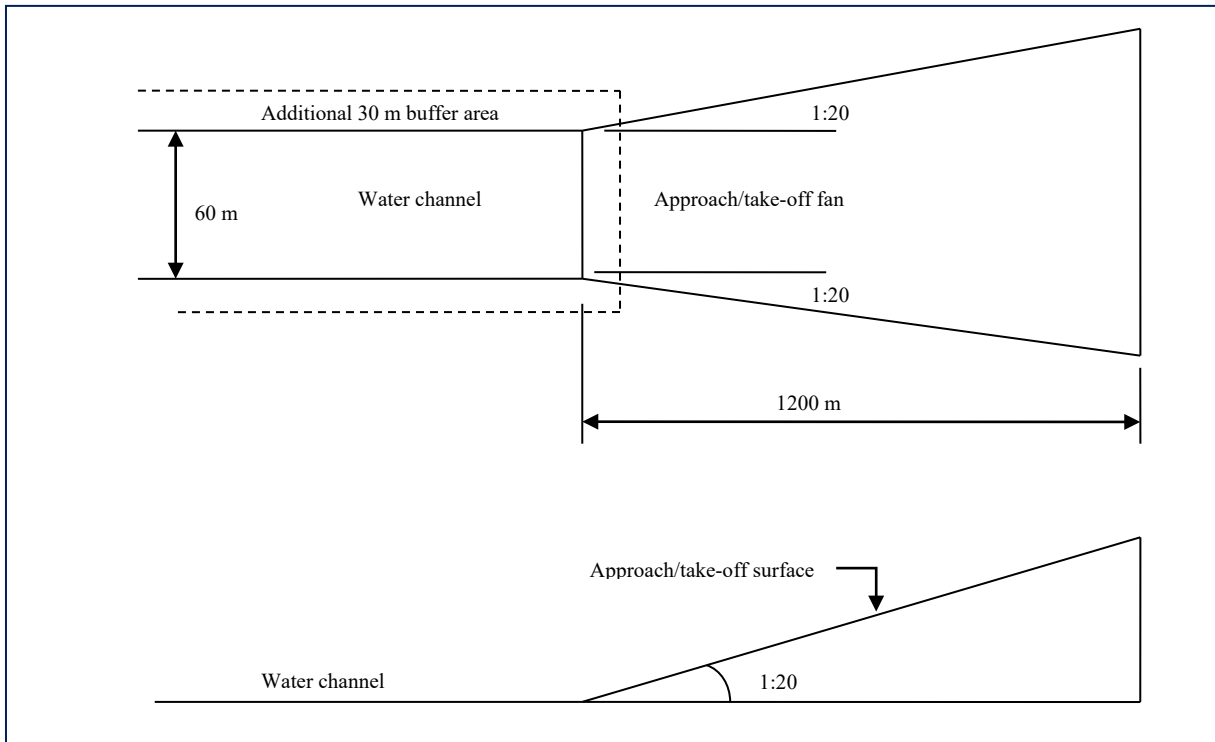

Figure 4-1. Water aerodrome obstacle limitation surfaces

This page is intentionally blank.

CHAPTER 5 — VISUAL AIDS FOR NAVIGATION

5.1 Wind direction indicator (Windsock)

5.1.1 Each runway should be provided with at least one windsock.

5.1.2 The windsock should be located so as to be visible both from an aircraft in flight and on the movement area.

5.1.3 For a day VFR runway, the windsock should be located at least 20 m from the runway centreline.

5.1.4 For a night VFR runway, the windsock should be illuminated and located at least 40 m from the runway centre line on the left hand side abeam the landing threshold.

5.1.5 For an instrument runway less than 800 m in length the windsock should be located at least 40 m from the runway centre line.

5.1.6 For an instrument runway of 800 m or more in length the windsock should be located at least 40 m from the runway centre line on the left hand side abeam the landing threshold.

5.2 Markers and markings

Threshold and runway designators

5.2.1 A runway designation marking should be provided:

- at the thresholds of a paved runway; and
- as far as practicable at the thresholds of an unpaved runway

On a paved runway, threshold and runway designator markings should be white and provided in accordance with Table 5-1 and Figure 5-1. For an unpaved runway where it is difficult to mark the runway surface, options include using a marker board (or similar) including the runway designator, or a concrete pad with the designator or concrete numbers embedded in the grass runway before or adjacent to the threshold.

5.2.2 For parallel runways the runway designation should be as follows:

- On parallel runways of the same physical surface the number should be supplemented by a letter L, C or R, preceding it longitudinally to designate left, centre or right runway.
- Parallel runways that clearly have different physical surfaces do not need to use the “L” or “R” letter supplement e.g. paved and grass or paved and pumice surface.

5.2.3 The threshold of a grass runway should be indicated by marker boards located either side of the threshold at right angles to the runway centre line. Where a marker board may create a hazard to taxiing aircraft, the marker board should be replaced with a white painted concrete strip of the same dimensions.

Table 5-1 Threshold markings for runways 23 m or below in width.

Runway width	Number of stripes	Stripe width	Stripe length
23 m	6	1500 mm	30 m
18 m	6	1250 mm	30 m
16 m	6	1250 mm	30 m
14 m	6	1100 mm	30 m
12 m	6	950 mm	30 m
10 m	6	800 mm	30 m
8 m	4	950 mm	20 m
6 m	4	700 mm	20 m

These dimensions give varying spaces between the outside stripe and the runway edge. Markings should be measured outwards from the centre line. For runway widths falling between the above, use spacing as for the narrower runway.

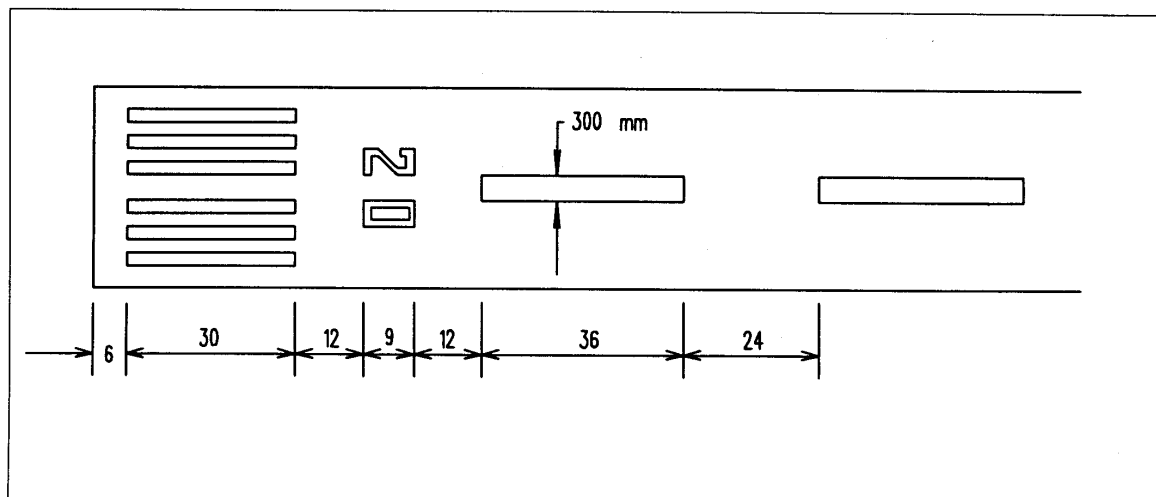

Figure 5-1. Runway markings

Displaced threshold

5.2.4 A permanently displaced threshold on a paved runway should be marked as shown in Fig. 5-2. The location of a temporary threshold on an unpaved runway, or a temporary threshold on a paved runway, should be indicated by wing bars of marker boards outside the runway edge.

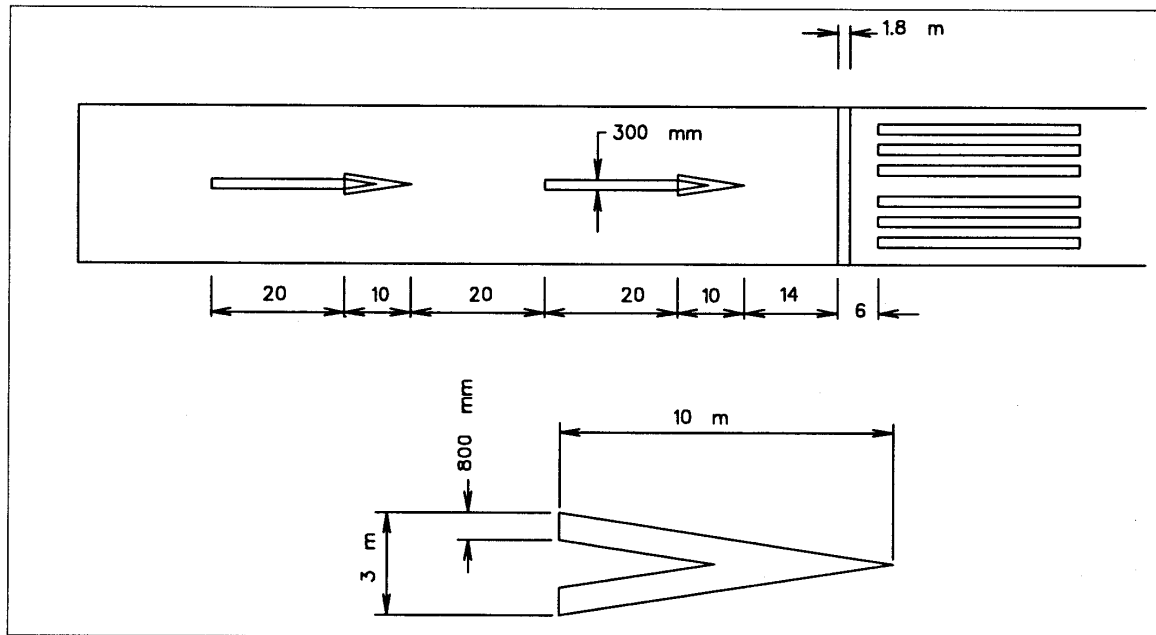

Figure 5-2. Displaced threshold markings

Runway centre line markings

5.2.5 Runway centre line markings should be provided on any paved runway 18 m or wider. They are located on the centre line of the runway and consist of a white line of uniformly spaced stripes and gaps. The stripes are 36 m in length and the gaps are 24 m in length. Adjustments to the length of the stripes and the gaps, where necessary to accommodate the runway length, are made near the mid-way point. The minimum width of the stripes is 0.3 m.

Runway edge markers

5.2.6 Runway edge markers should be provided where the extent of an unpaved runway is not clearly indicated by the appearance of its surface compared with that of the surrounding ground, and when the runway strip is not suitable for the movement of aircraft.

Markers for general use

5.2.7 Markers should be lightweight and frangibly mounted. Those located near a movement area should be sufficiently low to preserve clearance for propellers. They may be boards, cones, or white painted tyres.

5.2.8 A conventional marker board should be constructed to appear as illustrated in Fig. 5-3.

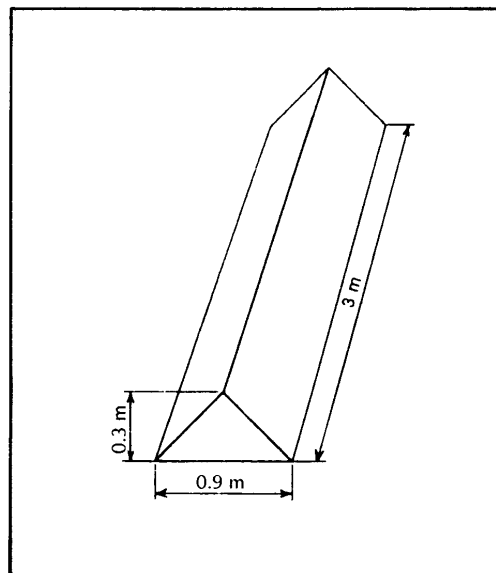

Figure 5-3. Marker board

5.3 Aerodrome lighting

Runway edge lights

5.3.1 Runway edge lights should be fixed omni-directional lights showing variable white and having a minimum output of 25 candela for fixed lighting, or 15 candela for portable lighting.

5.3.2 The lights should be two parallel rows equidistant from the runway centre line uniformly spaced in rows at intervals of not more than 100 m. The lights on opposite sides of the runway axis should be on lines at right angles to that axis and not more than 3 m outside the runway edge.

5.3.3 At intersections of runways, lights may be spaced irregularly or omitted, provided that adequate guidance remains available to the pilot.

Runway threshold lights

5.3.4 Runway threshold lights should be fixed unidirectional lights showing green in the direction of approach, located across the runway end between the runway edge lights. They should consist of not less than 4 equally spaced lights with the outer lights not closer than 1 m to the runway edge lights. The intensity and beam spread of the lights should be adequate for the conditions of visibility and ambient light in which the use of the runway is intended.

Runway displaced threshold lights

5.3.5 Where the threshold is displaced from the end of the runway, either temporarily or permanently, it should be lit by two wing bars each of four lights spaced at 5 m intervals with the inner light in line with the runway edge lights. The runway edge lights between the displaced threshold and the threshold should be bi-directional light fittings showing red/white, with the red light facing the landing pilot.

Runway end lights

5.3.6 Runway end lights should be fixed unidirectional lights showing red towards an aircraft taking off.

5.3.7 They should be placed as near to the runway end as possible, but not more than 3 m outside the end. They should be at least 4 lights equally spaced between the runway edge lights.

Starter extension lighting

5.3.8 Edge lights should be bi-directional red lights at the same spacing and installed in the same manner as the runway edge lights.

5.3.9 End lights should be at least 4 unidirectional lights, equally spaced across the end at not more than 3 m beyond the end, and showing red towards the runway.

5.3.10 Runway end lights, prior to the starter extension:

- (a) **Paved runway:** The lights should be flush mounted fixed unidirectional lights showing red towards the runway. The intensity and beam spread of the lights should be adequate for the conditions of visibility and ambient light in which the use of the runway is intended. Alternatively they may be in the form of wing bars as specified for unpaved runways.
- (b) **Unpaved runway:** The lights should be elevated at least 0.5 m, and consist of 4 lights in each of two wing bars at a light spacing of 5 m. The inner light on each side should be in line with the runway edge lights.

Taxiway edge lights

5.3.11 Taxiway edge lights should be fixed omni-directional lights showing blue and having a minimum output of 25 candela for fixed lighting, or 15 candela for portable lighting.

5.3.12 The lights should be two parallel rows equidistant from the taxiway centre line uniformly spaced in rows at intervals of not more than 60 m, or at a lesser distance that provides for the safe guidance of aircraft. The lights on opposite sides of the taxiway should be on lines at right angles to that axis and not more than 3 m outside the taxiway edge.

PAL lighting

5.3.13 Where a pilot activated lighting (PAL) VHF radio switching mechanism is installed it should comply with the following:

- (a) **Automatic PAL selection:** The PAL activated aerodrome lights switching should be so arranged so that the system is always automatically available at night and not dependent upon Air Traffic Services for a switch pre-selection.
- (b) **Keying:** The switch should operate on receipt of 5 rapid and short transmissions which collectively should not exceed 3 seconds from the first to the last transmission.
- (c) **Brightness:** The lights may have a short warm up period, but following this they should switch automatically to full brilliance.

Three levels of brilliance should be available. The control mechanism should be capable of, or have the provision for, the pilot to be able to vary the lighting intensity at any time by a further 4 similar short transmissions and a prolonged 5th one.

The lighting should cycle through the intensities as long as the 5th transmission continues, stopping at the pilot selected intensity when the transmit button is released.

- (d) **Selection of PAPI and other lighting facilities:** The equipment should be capable of turning on the PAPI, approach lights etc. The selection of those lights applicable to a particular runway should be part of the cycling pattern referred to. It will be so arranged that the cycling will:
 - (i) Turn on all lighting for a runway;
 - (ii) Cycle its brilliance (having 2.0 second dwells);
 - (iii) Change to the facilities for the reciprocal runway end;
 - (iv) Change to the next runway and repeat the procedure before reverting to the first runway and recommencing the whole cycle again, until the transmission ceases.

Where the switching is such that the full lighting facilities are turned on for a runway, regardless of direction of use, then the cycling will only apply to brilliance control.

- (e) **Duration of lighting:** The lights should remain on for 20 minutes. During this period any single transmission should reset the timer for a further 20 minutes.
- (f) **Lights to be activated:**
 - (i) runway, taxiway and tarmac edge lighting where it exists;
 - (ii) approach lights;
 - (iii) approach slope indicators;
 - (iv) lit wind direction indicators;
 - (v) the aerodrome beacon.
- (g) **Failure of software or electronic control:** In the event of a failure of the software or electronic switching, the lights should remain lit on the last selection made, until manual control is established.

5.4 Aerodrome lighting outages

5.4.1 Night operations should not be conducted when an outage exceeds the following figures.

Runway edge or end or threshold

5.4.2 A maximum of 20% random failure provided there are not more than two adjacent light failures in any 300 m.

Wind direction indicator

5.4.3 One should be serviceable.

5.5 Portable lighting

5.5.1 The lighting of runways, taxiways or apron edges with portable lights is acceptable provided the appropriate standards are met in relation to:

- (a) The physical dimensions and obstacle free gradients for the night use of the runway; and
- (b) the layout, spacing and colour of lights.

5.6 Reflectors

5.6.1 Where light fittings do not exist, reflectors may be installed at the following places, to assist in manoeuvring at night

- (a) runway centre line;
- (b) turning bay edges;
- (c) a taxiway centre line;
- (d) taxiway edges;
- (e) taxiway holding position;
- (f) apron centre lines; and
- (g) at apron edges.

5.6.2 In each of these locations the reflectors should be the same colour as the appropriate light would be, and at no greater spacing, but preferably closer.

5.7 Signs

Instruction signs that should be displayed

5.7.1 An instruction sign should be provided when it is intended to convey, by a sign, an instruction which is to be carried out unless otherwise advised by an air traffic service. Such instruction signs should include at least STOP and NO ENTRY signs.

5.7.2 A STOP sign should be located at least on the left side of a taxiway opposite the point at which it is desired that the aircraft stop.

5.7.3 A sign that requires compliance should be white inscriptions on a red background. If the sign is intended for use at night or under conditions of poor visibility it should be illuminated, either internally or externally.

Information signs

5.7.4 An information sign should be provided when it is intended to convey, by a sign, a specific location or destination on a movement area, or to provide other information.

5.7.5 An information sign should be either yellow or white inscriptions on a black background or black inscriptions on a yellow or white background. If it is to be used at night it should be illuminated either internally or externally, or coated with reflecting materials. Where a sign indicates a direction it should include an arrow indicating the direction, followed by the number, word or abbreviation that identifies the destination.

5.7.6 A sign by a taxiway indicating a destination should be on the same side of the taxiway as the direction to the location indicated.

The specifications for signs can be found in AC139-6 Chapter 5

5.8 Visual aids for denoting restricted use areas

Closed runway or taxiway

5.8.1 A marking or markers should be displayed on a runway or taxiway, or portion thereof, which is permanently closed to the use of all aircraft.

5.8.2 A marking or markers should be displayed on a temporarily closed runway, taxiway, or portion thereof.

5.8.3 When a runway or taxiway or portion thereof is permanently closed, all normal runway and taxiways markings should be obliterated.

5.8.4 Lighting on a closed runway or taxiway or portion thereof should not be operated, except as required for maintenance purposes.

5.8.5 The marking or markers should be in the form of a white cross with the minimum dimensions as shown in Fig. 5-4.

5.8.6 On a closed runway, or strip, a marking or markers should be placed at one third and two thirds the length of the closed runway.

5.8.7 On a closed taxiway a marking or markers should be placed at each end of the taxiway or closed portion.

Unserviceable areas

5.8.8 Unserviceable markings or markers should be displayed wherever any portion of a movement area is unserviceable.

5.8.9 They should consist of conspicuous upstanding devices such as flags, cones, lights or marker boards/tyres.

5.8.10 An unserviceable cone should not exceed 0.5 m in height and should be coloured red, orange or yellow or any one of these colours in combination with white.

5.8.11 An unserviceable marker should be painted white. A marker board should not exceed 0.3 m in height and 0.9 m in width. If longer than 3 m in length, the marker board should be marked with alternate red and white or orange and white vertical stripes. (see Figure 5-3)

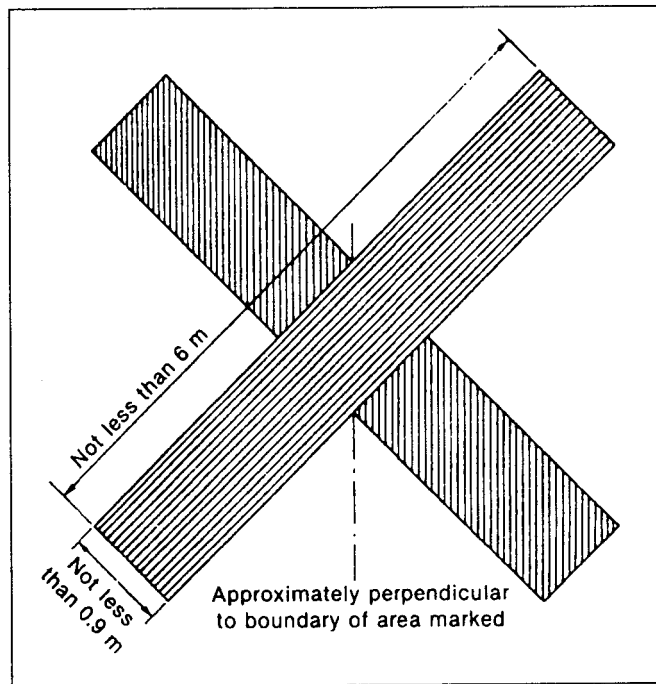

Figure 5-4. Marking for a closed runway, taxiway or portion thereof